

HTPB003

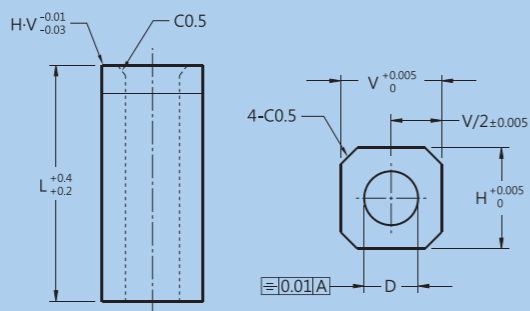

Type 品名	Material 材質	Hardness 硬度	Delivery 交貨日
HTPB003	H-V3~5 SKH51	61~64HRC	8 Working Days 8 個工作日
	H-V8~25 Equivalent to SKD11 SKD11同級	60~63HRC	

Type 品名	V	L	D	TOL.	H
HTPB003	3	7/10/13/17/19/22	1.6	+0.008 +0.002	3
	4	7/10/13/17/19/22	1.6/2.0	+0.008 +0.002	4
	5	11/15/17/20/25	2.5	+0.008 +0.002	5
	8	11/15/17/20/25	3/4	+0.012 +0.004	8
	10	11/15/17/20/25	3/4/5	+0.012 +0.004	10
	13	11/15/17/20/25	4/5/6	+0.012 +0.004	13
	13	11/15/17/20/25	8	+0.015 +0.007	13
	16	11/15/17/20/25	8/10	+0.015 +0.007	16
	20	11/15/17/20/25	10	+0.015 +0.007	20
	20	11/15/17/20/25	13	+0.018 +0.010	20
25	11/15/17/20/25	13/16	+0.018 +0.010	25	

Order Ex. 訂購範例

HTPB003-V-L-D

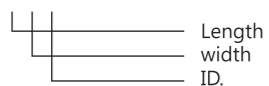

長度
寬度
內徑

Alterations 追加加工名稱	Description 加工說明	Order Ex. 訂購範例
LC	Full length change 變更全長 V · H : 3~5 7<L<25 V · H : 8~25 11<L<25 *0.1mm increments (If combined with LKC · LKZ, 0.01mm increments can be selected.) 指定單位0.1mm(與LKC · LKZ併用時可指定至0.01mm單位) *Punch fixing part (5±0.01) · Press-in lead length (3) Bolt counterbore depth (h) is the same as specified. 沖頭固定部 (5±0.01) · 導入部長度 (3) 螺栓刺入深度 (h) 同規格表。	HTPB003-3-10-1.6-LC
LKC	Full length tolerance change 變更全長公差 L +0.4 → +0.05 +0.2 → 0	HTPB003-3-10-1.6-LKC
LKZ	Full length tolerance change 變更全長公差 L +0.4 → +0.01 +0.2 → 0	HTPB003-3-10-1.6-LKZ
VKC2	V · H tolerance change 變更V · H公差 V · H +0.01 → V · H 0 0 → -0.005	HTPB003-3-10-1.6-VKC2
NDC	No press-in lead 無導入部	HTPB003-3-10-1.6-NDC